

---

## Patterns in Prague

This problem gives you the chance to:

- calculate the area of a complex shape
  - calculate the perimeter of a shape using Pythagoras' Rule
- 

Prague is an ancient city in the Czeck Republic.

In Prague some of the sidewalks are made from small square blocks, **5 cm by 5 cm**.

The blocks are in different shades to make patterns.

This is one of the patterns they make.

In this pattern some triangular blocks are made by cutting a square in half diagonally.

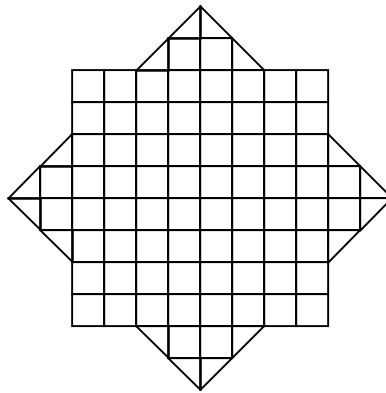

1. Find the area of this pattern.  
Show how you figured it out.

\_\_\_\_\_ cm<sup>2</sup>

2. Calculate the perimeter of the pattern.  
Show how you figured it out.

\_\_\_\_\_ cm

Patterns in Prague	Rubric	
<ul style="list-style-type: none"> <li>•</li> <li>• The core elements of performance required by this task are:               <ul style="list-style-type: none"> <li>• calculate the area of a complex shape</li> <li>• calculate the perimeter of a shape using Pythagoras' Rule</li> </ul> </li> <li>•</li> </ul> <p>Based on these, credit for specific aspects of performance should be assigned as follows</p>	points	section points
<p>1. Gives correct answer: <b>2000</b> cm<sup>2</sup></p> <p>Shows correct work such as: <math>8^2</math>  <math>+ 4 \times 4 = 80</math> blocks  <math>80 \times 5^2</math></p>	<p>1</p> <p>1</p> <p>1</p> <p>1ft</p>	<p>4</p>
<p>2. Gives correct answer: 192 to 194 cm or <math>80 + 80\sqrt{2}</math></p> <p>Shows correct work such as: <math>\sqrt{(10^2 + 10^2)} = \sqrt{200} = 14.14</math> or <math>10\sqrt{2}</math>  <math>14.14 \times 8 + 10 \times 8</math></p>	<p>1</p> <p>2</p> <p>1</p>	<p>4</p>
<b>Total Points</b>		<b>8</b>

## Patterns in Prague

Work the task. Look at the rubric. What are some of the key mathematical ideas that students need to understand to work this task?

---



---

Look at the diagrams. How many of your students:

- Used the diagram as a tool and marked it up to help them think about the situation? \_\_\_\_\_
- How many students made additional diagrams to assist their thinking? \_\_\_\_\_
- How many papers have blank diagrams? \_\_\_\_\_

Look at student work for part 1. How many of your students put:

2000	80	64	144	44	Other

Did you see evidence of students thinking about scale factors?

Did they understand that the area would 25 times larger rather than only 5 times larger?

How many students ignored scale factor?

Could students find the area of the center square?

How did students find the area of the other corners?

Now look at work for the perimeter of the shape in part 2. How many of your students put:

192-194	32	24	64	80	160	20	No answer	Other

How many of the students forgot scale factor?

How many students counted the diagonals as the same size as the legs of the triangles?

Did you see evidence of students using Pythagorean theorem?

What other errors did you notice in student work?

## Looking at Student Work on Patterns in Prague

To look at student work, it is important to have 3 main solution strategies in mind as student work varies depending on when they apply or don't apply the scale factor. Work also varies depending on how the students think about the triangles with diagonal edges. Are they looking at 16 small triangles with an edge of 1 or 5? Are they looking 8 triangles with base of 2 and height of 2 (base of 10 and height of 10)? Or are they thinking about 4 triangles with a base of 4 and height of 2 (base of 20 and height of 10)? All of these paths lead to the same final solution, but to analyze mistakes the intermediary steps need to be considered.

### Solution Strategies for Patterns in Prague

#### Part 1 - Area

Path 1

*Area of large square*

$$8 \times 8 = 64$$

*area of small triangle*

$$(2 \times 4) / 2 = 4$$

*area of all small triangles*

$$4 \times 4 = 16$$

*Total area without scale factor*

$$64 + 16 = 80$$

*With scale factor*

$$80 \times 25 = 2000$$

Path 2

*Area of large square*

$$40 \times 40 = 1600$$

*Area of small triangle*

$$(10 \times 20) / 2 = 100$$

*Area of all small triangles*

$$4 \times 100 = 400$$

*Total area with scale factor*

$$1600 + 400 = 2000$$

#### Part 2 - Perimeter

Path 1

*Perimeter of 4 triangles*

$$2 + 2 = 4$$

$$4 \times 4 = 16$$

$$16 \times 5 = 80 \text{ (scale)}$$

*Size of diagonal smallest triangle*

$$1^2 + 1^2 = 2$$

$$\text{diagonal} = \sqrt{2} \approx 1.4$$

$$1.4 \times 16 = 22.6$$

*with scale factor*

$$22.6 \times 5 = 113.17$$

*Total perimeter*

$$113.17 + 80 = 193.17$$

Path 2

*Perimeter of 4 triangles*

$$10 + 10 = 20$$

$$20 \times 4 = 80$$

*Diagonal of larger triangle*

$$2^2 + 2^2 = 8$$

$$\text{diagonal} = \sqrt{8} \approx 2.8$$

$$2.8 \times 4 = 22.6$$

*with scale factor*

$$22.6 \times 5 = 113.17$$

*Total perimeter*

$$113.17 + 80 = 193.17$$

Path 3

*Diagonal with scale*

$$10^2 + 10^2 = 200$$

$$\text{diag.} = 10\sqrt{2} \approx 14.14$$

$$14.14 \times 8 = 113.14$$

The best papers available in the sample papers had scores of 4 or 5 out of the 8 points. No student in the sample was thought to apply Pythagorean theorem to find the lengths of the diagonals. This is a seventh grade standard.

*Are students in these classrooms given the opportunity to learn important mathematical concepts?*

Student A uses labels on the calculations for area in part 1. The student understands and can apply scale factor to area. The student thinks about combining the diagonal triangles to make squares in order to avoid using the formula for area of a triangle and so uses an incorrect side measurement to find the area. The student was lucky that the areas came out the same. *For this strategy to work, what would the student have to use as a side measurement?* Notice that in finding the perimeter the student counts the diagonals and legs of the small squares as the same size. *How do we help students notice the basic attribute of right triangles that the hypotenuse is larger than the leg?* The understanding of scale factor is fragile for this student and is not used in part 2 of the task.

**Student A**

This is one of the patterns they make.

In this pattern some triangular blocks are made by cutting a square in half diagonally.

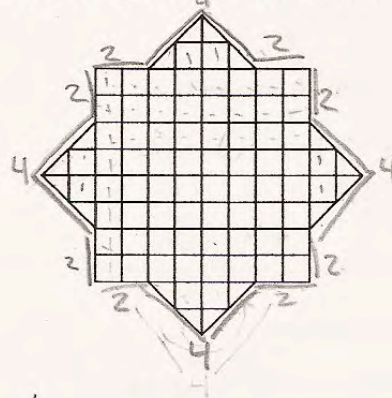

1. Find the area of this pattern.

Show how you figured it out.

$$8 \cdot 8 = 64 \checkmark \checkmark$$

$$5 \cdot 5 = 25 \checkmark \checkmark$$

$$64 - 25 = 1600$$

$$1600 + 400 = 2000 \checkmark \checkmark$$

2 \cdot 4 = 8  
 (2 whole squares in each triangle)  
 8 + 8 = 16  
 16 \cdot 25 = 400  
 2 \cdot 4 = 8  
 (4 triangles made 2 squares per big triangle)

2000 ✓ cr

2. Calculate the perimeter of the pattern.

Show how you figured it out.

$$4 \cdot 4 = 16$$

$$2 \cdot 8 = 16 \quad \times \times$$

$$16 \cdot 2 = 32$$

32 ✗ cr

Student B is able to correctly think about the area of the diagonal triangles and uses a diagram to show how to rearrange the parts to make a square. The student applies the scale factor of 25 for area to get a correct solution in part 1. The student seems to notice that not all the sides are the same length when trying to calculate perimeter. However some diagonals are counted as 1 unit and other diagonals are counted as 2. (1,2,3-4)the legs of the square are also counted as 1. The student does correctly apply a linear scale factor to the solution.

**Student B**

This is one of the patterns they make.

In this pattern some triangular blocks are made by cutting a square in half diagonally.

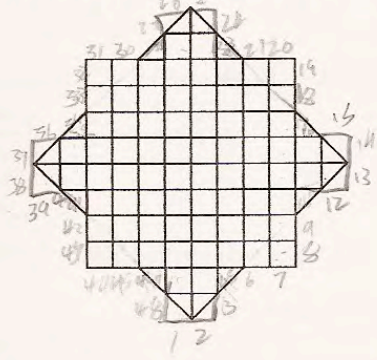

1. Find the area of this pattern.  
Show how you figured it out.

There are 80 squares  
each square 25 cm.  
 $80 \times 25 = 2000$

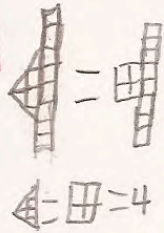

2000 cm<sup>2</sup>

2. Calculate the perimeter of the pattern.  
Show how you figured it out.

$48 \times 5 = 240$

240 cm

Student C applies scale directly to the diagram and can use the formula for area of a triangle in part 1. The student clearly sees the diagonal and side length as the same size when finding perimeter. The student calculates the perimeter for each square separately, assuming that they are not on top of each other and so doubles the answer for the perimeter of 1 square.

**Student C**

This is one of the patterns they make.

In this pattern some triangular blocks are made by cutting a square in half diagonally.

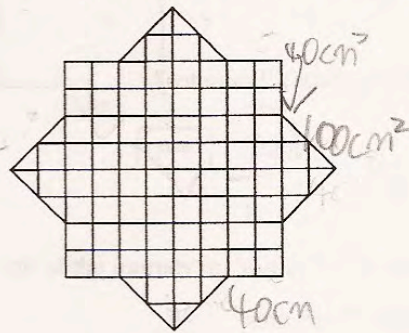

1. Find the area of this pattern.  
Show how you figured it out.

Handwritten work for question 1:

- Diagram of a triangle with base 20cm and height 10cm. Calculation:  $20 \cdot 10 \cdot 5 = 100 \text{ cm}^2$ . A checkmark is next to it.
- Diagram of a square with side length 40cm. Calculation:  $40 \cdot 40 = 1600 \text{ cm}^2$ . A checkmark is next to it.
- Final calculation:  $1600 + 400 = 2000 \text{ cm}^2$ . A checkmark is next to the final answer.

2. Calculate the perimeter of the pattern.  
Show how you figured it out.

Handwritten work for question 2:

- Diagram of a square with side length 40cm. Calculation:  $40 + 40 = 80$ . A checkmark is next to it.
- Diagram of a triangle with base 20cm and height 10cm. Calculation:  $20 + 10 + 20 = 50$ . A checkmark is next to it.
- Diagram of a triangle with base 20cm and height 10cm. Calculation:  $20 + 10 + 20 = 50$ . A checkmark is next to it.
- Diagram of a triangle with base 20cm and height 10cm. Calculation:  $20 + 10 + 20 = 50$ . A checkmark is next to it.
- Final calculation:  $80 + 160 + 160 = 320 \text{ cm}$ . A checkmark is next to the final answer.

Student D is able to find the area of the small triangles and the large square and add them together for a total area of 80. The student attempts to apply the scale factor to the solution, but doesn't understand that the 5 needs to be squared because area is a square measurement. The student sees the diagonals as the same size as the legs of the small squares. Notice that the student rearranges the small triangles into a new configuration with 8 edges instead of 4. *Can you figure out where the 8 comes from?* The student doesn't understand that while moving pieces does not change the area it may change the perimeter. The student does not attempt to use scale in part 2.

**Student D**

This is one of the patterns they make.

In this pattern some triangular blocks are made by cutting a square in half diagonally.

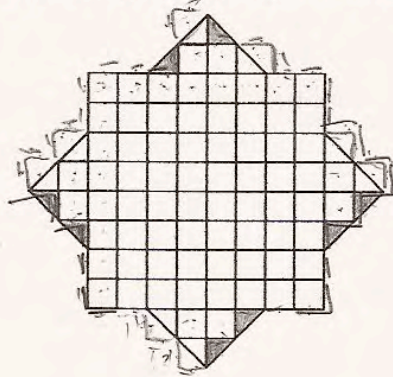

1. Find the area of this pattern.  
Show how you figured it out.

$$\begin{array}{r} 16 \checkmark \\ + 64 \checkmark \\ \hline 80 \end{array} \quad \times \quad \begin{array}{r} 80 \\ 5 \\ \hline 400 \end{array}$$

400

---

2. Calculate the perimeter of the pattern.  
Show how you figured it out.

$$\begin{array}{r} 8 \\ \times 4 \\ \hline 32 \end{array} \quad \begin{array}{r} 4 \\ \times 4 \\ \hline 16 \end{array} \quad \begin{array}{r} 32 \\ + 16 \\ \hline 48 \end{array} \quad \times \quad \times \times$$

48

---



Student E is able to find the area of the drawing in part 1 and uses the formula for area of a triangle. Notice the diagram used to help think about how to find the area of the triangles. The student does not use scale factor. In part 2 the lengths of diagonals and legs are seen as equal and the student miscounts.

**Student E**

This is one of the patterns they make.

In this pattern some triangular blocks are made by cutting a square in half diagonally.

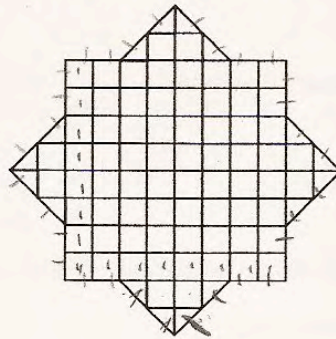

1. Find the area of this pattern.  
Show how you figured it out.

$8 \times 8 = 64$  ✓       $16 + 64 = 80$

80 ✗ cr

2.  $2 \times 4 = 8$   
 $8 \div 2 = 4$   
 $4 \times 4$  (triangle) = 16 ✓

2. Calculate the perimeter of the pattern.  
Show how you figured it out.

I simply counted all of the squares facing the outside.

31 ✗ cr

Student F is able to find the area of the large square and the triangles. The area of the triangle is most likely found by counting squares and half-squares. The student uses the same strategy when trying to find the perimeter. Two sides of half a square equals a whole side length or 1. So the diagonal triangles have a perimeter of 2. The student ignores scale.

**Student F**

This is one of the patterns they make.

In this pattern some triangular blocks are made by cutting a square in half diagonally.

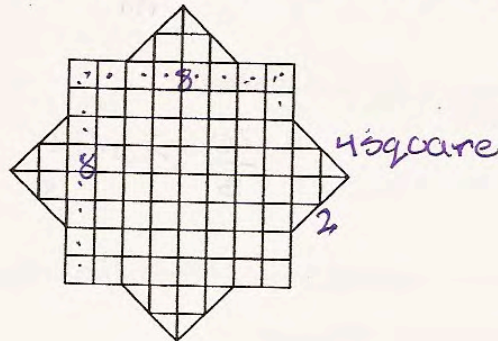

1. Find the area of this pattern.  
Show how you figured it out.

$$\begin{array}{r}
 4 \times 4 = 16 \\
 8 \times 8 = 64 \\
 \hline
 80
 \end{array}$$

80 X cm

2. Calculate the perimeter of the pattern.  
Show how you figured it out.

2 per Triangle

$$\begin{array}{r}
 2 \times 4 = 8 \\
 + 8 \\
 \hline
 16
 \end{array}$$

3 per corner of square

$$2 \times 4 = 8$$

16 X cm

Student G counts the edge of the small squares for one triangle and then 1/2 an edge for the diagonals around another triangle and then treats them as if combined they equaled the side of a rectangle or square. *How can we help students notice that diagonals are longer than the sides of a square? How can we help students understand formulas that that they are applied in such a random fashion? What would be your next steps with this student?*

**Student G**

This is one of the patterns they make.

In this pattern some triangular blocks are made by cutting a square in half diagonally.

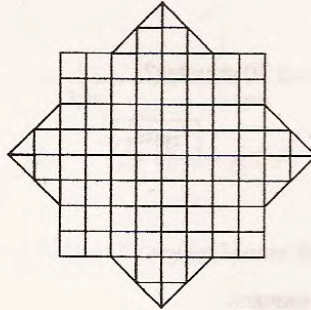

1. Find the area of this pattern.

Show how you figured it out.

$$5 + 5 + 5 + 5 = 20 = 30$$

$$2.5 + 2.5 + 2.5 + 2.5 = 10 \quad 30 \times 30 = 900 \times \times$$

$$5 + 5 + 5 + 5 = 20 = 30$$

$$2.5 + 2.5 + 2.5 + 2.5 = 10 \times \times$$

$$\underline{900 \times \times} \text{ cm}^2 \quad \begin{matrix} 00 \\ 00 \\ 00 \\ 00 \end{matrix}$$

2. Calculate the perimeter of the pattern.

Show how you figured it out.

$$5 + 5 + 5 + 5 \cdot 4 = 80 \checkmark$$

$$8 + 4 = 12$$

$$2.5 + 2.5 + 2.5 + 2.5 = 10 \cdot 4 = 40 \times$$

$$\underline{120 \times \times} \text{ cm} \quad \begin{matrix} 00 \\ 00 \\ 14 \end{matrix}$$

Student H does not appear to have any concept of perimeter. In part 1 the student finds the area of a small square, rather than decomposing the larger figure and finding the area of the total shape. In part 2 the student finds the area of the large square. *How do you think the student got the 20 for the area of the 4 diagonal triangles? Would labeling the calculations have helped this student? How would you help this student?*

**Student H**

This is one of the patterns they make.  
 In this pattern some triangular blocks are made by cutting a square in half diagonally.

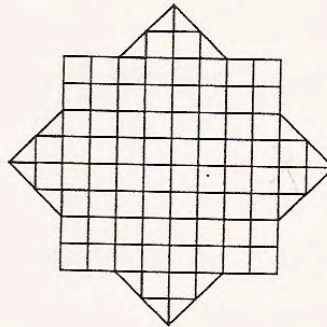

1. Find the area of this pattern.  
 Show how you figured it out.

$$5 \times 5 = 25 \checkmark$$

$$\begin{array}{r} 75 \times \\ \hline \text{cm}^2 \\ 0 \\ 0 \\ 0 \\ 1 \end{array}$$

2. Calculate the perimeter of the pattern.  
 Show how you figured it out.

$$\begin{array}{r} 8. \\ \hline 64 \\ + 20 \\ \hline 84 \end{array}$$

$$\begin{array}{r} 84 \times \\ \hline \text{cm} \\ 0 \\ 0 \\ 0 \end{array}$$

While the answers for Student I are not typical, the process is seen in a number of papers. The student seems to have an internal algorithm that if there is a lot of space given, then there should be a lot of calculations. The student takes random numbers from the problem and adds or multiplies. *Can you see any sense-making in the work?*

**Student I**

This is one of the patterns they make.

In this pattern some triangular blocks are made by cutting a square in half diagonally.

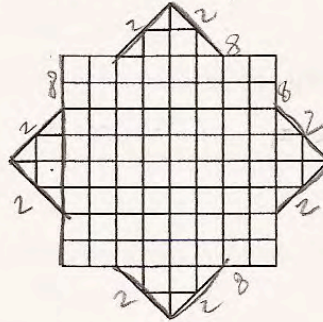

1. Find the area of this pattern.

Show how you figured it out.

$$\begin{aligned}
 8 \times 5 &= 40 && \times \\
 40 \times 9 &= 160 \\
 2 \times 5 &= 10 && \times \\
 10 \times 4 &= 40 \\
 160 \times 40 &= 6400
 \end{aligned}$$

$$\frac{6400}{\text{cm}^2} \times$$

2. Calculate the perimeter of the pattern.

Show how you figured it out.

$$\begin{aligned}
 8 \times 5 &= 40 && \times \\
 40 \times 9 &= 160 \\
 2 \times 5 &= 10 \\
 10 \times 9 &= 90 \\
 40 + 160 &= 200 && \times
 \end{aligned}$$

$$\frac{200}{\text{cm}} \times$$

<i>Student Task</i>	Calculate the area of a complex shape. Calculate the perimeter of a shape using Pythagoras' Theorem.
<b>Core Idea 4 Geometry and Measurement</b>	<p><b>Analyze characteristics and properties of 2- and 3- dimensional shapes; develop mathematical arguments about geometric relationships; and apply appropriate techniques, tools and formulas to determine measurements.</b></p> <ul style="list-style-type: none"> <li>• Create and critique inductive and deductive arguments concerning geometric ideas and relationships and the Pythagorean relationship.</li> </ul>

*The mathematics of this task:*

- Composing and decomposing shapes into simpler parts
- Finding areas of triangles by using a diagram to find the base and height
- Finding area of a square
- Using scale factor to find actual measurements for a diagram
- Using Pythagorean theorem to find length of a hypotenuse
- Finding perimeter of a complex figure

*Based on teacher observation, this is what eighth graders know and are able to do:*

- Students knew how to find the area of a square
- Students understood that perimeter was the distance around the outside of the shape
- Students could count squares and half-squares

*Areas of difficulty for eighth graders:*

- Visualizing the difference in size between the diagonal and side length of the small squares
- Using the formula for finding area of a triangle
- Applying scale factor to a diagram
- Using a diagram as a tool for thinking
- Recognizing equal size parts
- Understanding that perimeters may change when pieces are re-arranged
- Counting the diagonals of squares as half a unit

### Task 3 - Patterns in Prague

Mean: 1.18      StdDev: 1.71

Table 42: Frequency Distribution of MARS Test Task 3, Grade 8

Task 3 Scores	Student Count	% at or below	% at or above
0	874	47.0%	100.0%
1	420	69.5%	53.0%
2	371	89.5%	30.5%
3	26	90.9%	10.5%
4	79	95.1%	9.1%
5	14	95.9%	4.9%
6	19	96.9%	4.1%
7	9	97.4%	3.1%
8	49	100.0%	2.6%

Figure 51: Bar Graph of MARS Test Task 3 Raw Scores, Grade 8

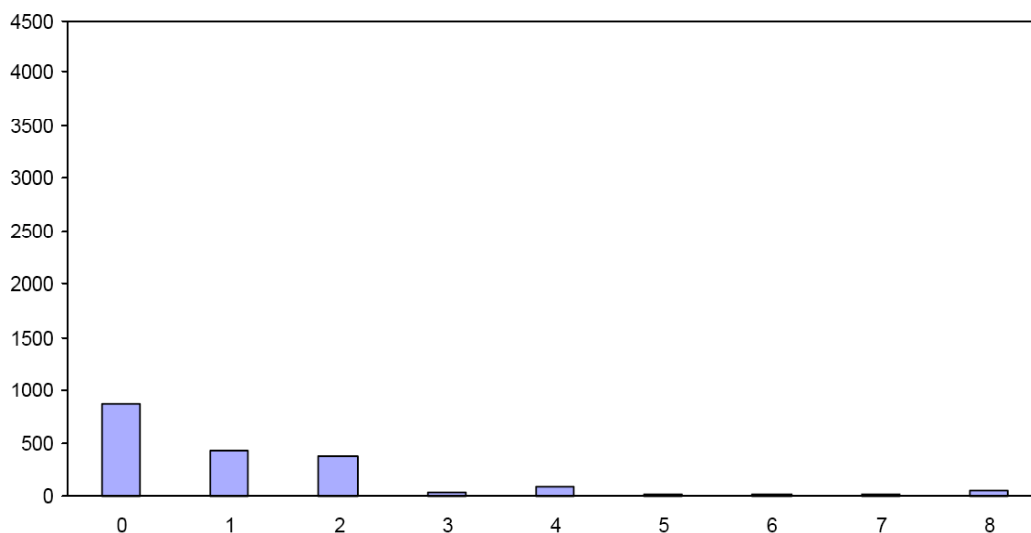

*The maximum score available for this task is 8 points.*

*The minimum score for a level 3 response, meeting standards, is 5 points.*

About half the students, 53%, could find the area of the large square. Some students, about 30%, could also find the area of the small triangles, usually by counting squares and half-squares rather than using the formula. Less than 10% of the students could find the area of the complex shape in part 1 and apply scale factor to the diagram. Less than 3% of the students could find the perimeter of the shape. 47% of the students scored no points on this task. 88% of the students with this score attempted the task.

## Patterns in Prague

Points	Understandings	Misunderstandings
<b>0</b>	88% of the students with this score attempted the task.	Students could not find the area of the large square, with or without scale.
<b>1</b>	Students could find the area of the large square but did not apply scale.	Students did not know how to find the area of a triangle.
<b>2</b>	Students could find the area of the square and the triangle, but did not apply scale.	Some students did not realize that the scale factor is squared when finding area and just multiplied by 5.
<b>4</b>	Students could find the area of a complex shape, consisting of a square and 4 triangles. Students could apply scale to a drawing to find the true measurements.	Students did not understand that the diagonal of a square was not the same size as the side length. 25% had a perimeter of 32 and 7% had 160 (32 x 5). Students, even those who used scale in part 1, usually did not use scale in part 2.
<b>5</b>	This is an atypical score. The students miscalculated the area of triangle in part 1. The student did use Pythagorean theorem but did not use scale factor in part 2.	Students did not use Pythagorean theorem in part 2, finding the lengths of the sides.
<b>8</b>	Students could calculate area and perimeter of a complex shape by decomposing it into simpler parts. Students could apply scale to a diagram to calculate measures. Students recognized the diagonals were a different size than the sides of the small square and could apply Pythagorean theorem to find the lengths of the diagonals.	



## Implications for Instruction

Students at this level need opportunities to work with shapes and their attributes. Students should do physical activities like folding papers to see that diagonal of a square is a different length than the side or using sticks of different lengths to test when a triangle is possible or not possible. Students would benefit from more concrete experiences to help them identify properties when confronted with problems.

Students should be given more problems with area and perimeter that have a higher cognitive demand than just using arithmetic skills of multiplication or addition. Students should be pushed to think about formulas and how and why they work, rather than counting squares. Students should be comfortable working with more complex figures than simple shapes encountered at earlier grade levels. The new skills for middle grades should include understanding diagrams and scale factors. Students should have opportunities to work with growing shapes in 2- and 3- dimensions to see how scale effects the measurements or side length, area, and volume.

Students need to be exposed to rich and interesting mathematics, including working with Pythagorean theorem, a 7<sup>th</sup> grade state standard. They should have opportunities to solve problems like the height of flagpoles to see the usefulness of this in everyday life. Looking at student papers, the question of opportunity to learn is one of concern.

## Ideas for Action Research – Investigating Complex Shapes

Too often, standard textbooks offer students at all grade levels simple diagrams for finding area and perimeter, where students only need to practice arithmetic skills with little attention or need to think about geometric properties. Consider this page:

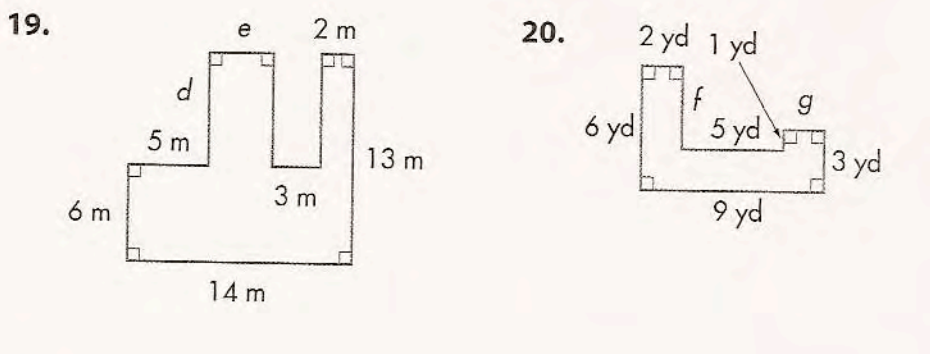

Even though unknowns have been added to give the pretext of algebra, the type of thinking is mostly arithmetic.

Now consider a different set of problems:

4. Find the area of each shaded figure.

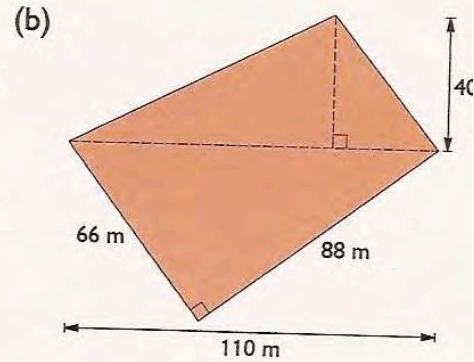
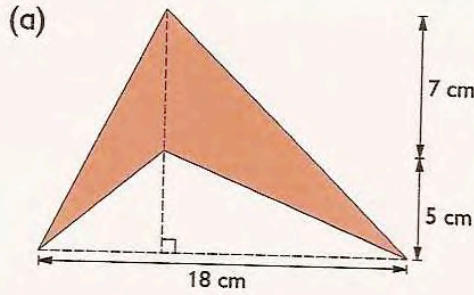

70

Find the shaded area of each rectangle.

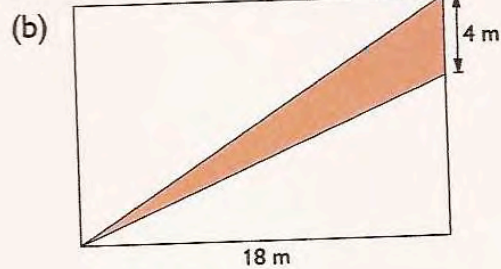
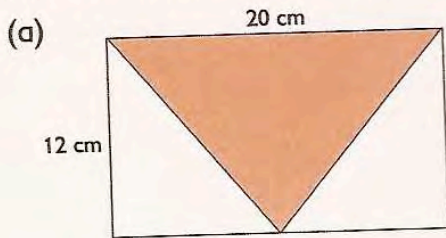

Both sets of problems are from 6<sup>th</sup> grade books. When moving to higher grades, students need to be presented with larger chains of reasoning that focus attention on the geometric relationships instead of just practicing arithmetic skills.

### Ideas for Action Research – Growing Patterns

An interesting investigation is to have students use pattern blocks to build similar figures and compare how the area grows with each increasing shape. Students should notice that it always takes four smaller shapes to make the next larger shape or that the increase in blocks is always a square number. You might modify the Problem of the Month from the Noyce website, Tri-triangles part C.

### Level C:

Anne uses triangles to make the following patterns:

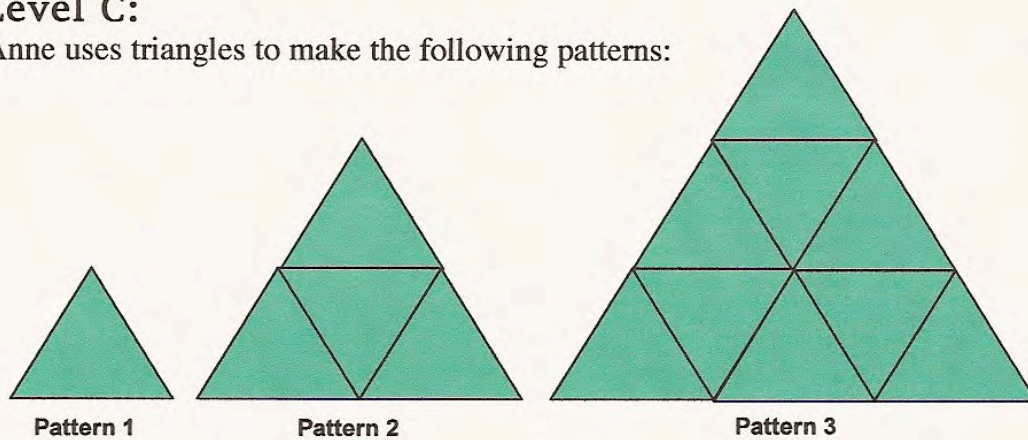

The pattern continues in the same geometric design.  
Draw Pattern 4, how many triangles are needed?

How many triangles are needed to construct Pattern 7?

How many triangles are needed to construct Pattern 16?  
Explain how you determined your rule.

Write a rule to find the number of triangles needed for the  
nth pattern? Explain your rule.

Suppose a pattern had 2,025 triangles, what is the pattern  
number?  
Explain.

Performance Assessment Task				
Patterns in Prague Grade 8				
<p>The task challenges a student to demonstrate understanding of the concepts of area and perimeter of a complex figure. A student must understand the difference between area and perimeter. A student must make sense of the relationship between squares and triangles to determine the area of this complex shape. A student must make sense of the Pythagorean Theorem to find the distance of the side of right triangles in the complex figure in order to determine the perimeter of the complex shape.</p>				
Common Core State Standards Math - Content Standards				
<p><b><u>Geometry</u></b>  <b>Understand and apply the Pythagorean Theorem.</b>            8.G.7 Apply the Pythagorean Theorem to determine unknown side lengths in right triangles in real-world and mathematical problems in two and three dimensions.</p>				
Common Core State Standards Math – Standards of Mathematical Practice				
<p><b>MP.5 Use appropriate tools strategically.</b>            Mathematically proficient students consider the available tools when solving a mathematical problem. These tools might include pencil and paper, concrete models, a ruler, a protractor, a calculator, a spreadsheet, a computer algebra system, a statistical package, or dynamic geometry software. Proficient students are sufficiently familiar with tools appropriate for their grade or course to make sound decisions about when each of these tools might be helpful, recognizing both the insight to be gained and their limitations. For example, mathematically proficient high school students analyze graphs of functions and solutions generated using a graphing calculator. They detect possible errors by strategically using estimation and other mathematical knowledge. When making mathematical models, they know that technology can enable them to visualize the results of varying assumptions, explore consequences, and compare predictions with data. Mathematically proficient students at various grade levels are able to identify relevant external mathematical resources, such as digital content located on a website, and use them to pose or solve problems. They are able to use technological tools to explore and deepen their understanding of concepts.</p> <p><b>MP.6 Attend to precision.</b>            Mathematically proficient students try to communicate precisely to others. They try to use clear definitions in discussion with others and in their own reasoning. They state the meaning of the symbols they choose, including using the equal sign consistently and appropriately. They are careful about specifying units of measure, and labeling axes to clarify the correspondence with quantities in a problem. They calculate accurately and efficiently, express numerical answers with a degree of precision appropriate for the problem context. In the elementary grades, students give carefully formulated explanations to each other. By the time they reach high school they have learned to examine claims and make explicit use of definitions.</p>				
Assessment Results				
<p>This task was developed by the Mathematics Assessment Resource Service and administered as part of a national, normed math assessment. For comparison purposes, teachers may be interested in the results of the national assessment, including the total points possible for the task, the number of core points, and the percent of students that scored at standard on the task. Related materials, including the scoring rubric, student work, and discussions of student understandings and misconceptions on the task, are included in the task packet.</p>				
Grade Level	Year	Total Points	Core Points	% At Standard
8	2008	8	5	5 %